

U.S. Pat. No. 6,263,929

Making your own dowel has never been easier. The Veritas® Dowel Maker lets you make perfectly sized dowel from 1/4" to 1" diameter in 1/16" increments, from any wood species you wish.

An electric drill and drive socket are used to spin square stock past the stationary blades on the dowel maker. The process uses two wear-resistant A2 tool steel blades mounted on micro-adjustment mechanisms. The front blade transforms the square stock into an oversize dowel, cutting aggressively and leaving a rough finish. The rear blade sizes the dowel to its final diameter, leaving a much finer finish.

An exploded view of the dowel maker is shown below to identify the various components.

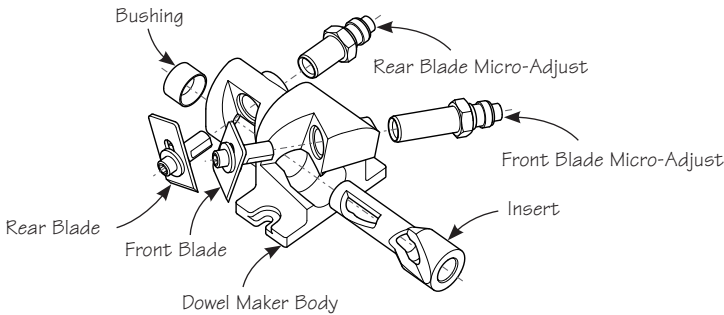

**Figure 1: Exploded view of Veritas® Dowel Maker.**

 **Caution:** *Blades are extremely sharp! Use caution when handling the blades. Do not run your finger in either cut-out to clear chips, or for any other reason.*

 **Caution:** *Always wear safety glasses when using this tool.*

### Mounting Your Dowel Maker

The body has two notches that allow it to be securely bolted or screwed to the top of a workbench. These notches are sized to take any type of fastener from #10 to 5/16". Simply place the dowel maker on your workbench and mark the notch locations. We suggest placing it near the end of your workbench so that there is plenty of room for the exiting dowel.

For a permanent installation on benches that are at least 1" thick, use lag screws with washers, as shown in **Figure 2**. For thinner benches, use bolts through the bench top secured with nuts on the bottom. Alternatively, install threaded inserts into your bench top for use with machine screws or bolts.

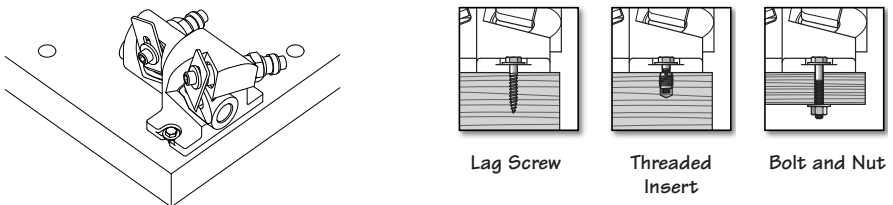

**Figure 2: Dowel maker mounting options.**

The optional Dog-Hole Mount Assembly (05G20.02) allows you to secure the dowel maker onto a bench top through a 3/4" diameter bench dog hole (see **Figure 3**).

### Using Dowel Supports

Depending on the diameter and length of the dowel being made, there may be a tendency for it to whip about. This can affect the accuracy and finish of the dowel and, in extreme cases, cause the dowel to break. As a guideline, 1/4" diameter dowel needs to be supported every 8". Dowel between 1/4" and 5/8" will need to be supported every 12", and all dowel larger than 5/8" will need to be supported every 15". **Figure 4** illustrates a typical set-up for running dowel.

*Note: Bear in mind that even with proper support, there is still a finite dowel length that can be achieved. Square stock must be able to withstand the torque applied by the drive socket, while the opposite end is resisted by the dowel maker. The greater the length, the greater the opportunity for the square blank to twist and potentially fail. The maximum length is variable, depending on wood species, dryness, knots, etc.*

Shop-made V-blocks work well as dowel supports. Softwood is recommended in order to reduce the chance of burnishing your dowel. Cut a V along the length of a 2x4, as shown in **Figure 5**. Cut this 2x4 into as many 3" pieces as you will require supports. These will be placed upon your workbench when making your first test dowel.

### Preparing Your Stock

The dowel maker is designed to make dowels from square stock with minimum waste. For dowel in 1/8" increments, use square stock that is 1/8" oversize; for dowel in 1/16" increments, use square stock that is 3/16" oversize. This is summarized in **Table 1**.

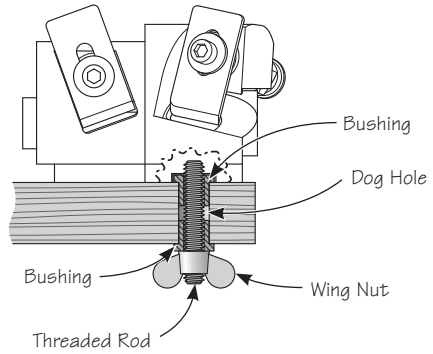

**Figure 3: Dowel maker mounted with dog-hole mount assembly.**

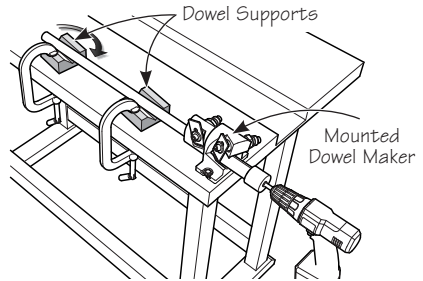

**Figure 4: Typical set-up for running dowel.**

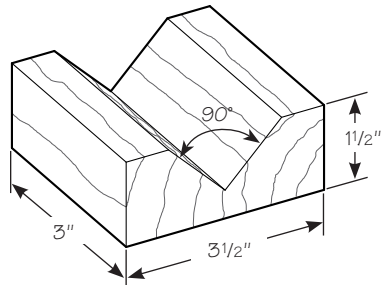

**Figure 5: Shop-made dowel support.**

**Table 1: Dowel stock size requirements.**

Dowel Size	Square Stock Size
1/4"	3/8"
5/16"	1/2"
3/8"	1/2"
7/16"	5/8"
1/2"	5/8"
9/16"	3/4"
5/8"	3/4"
11/16"	7/8"
3/4"	7/8"
13/16"	1"
7/8"	1"
15/16"	1 1/8"
1"	1 1/8"

### Using the Dowel Maker

The basic dowel maker comes with the necessary parts and accessories to make 15/16" and 1" dowel. Optional inserts are available for making dowel from 1/4" to 7/8", in 1/16" increments.

*Note: Before making dowel out of exotic wood, you should start with scraps of a common wood (with a similar density) on which you can first make the necessary adjustments.*

### Setting the Blades

*Note: Do not loosen either of the blade cap screws. The blades come sharpened and the proper projection has already been set. Should you accidentally loosen them, see the Blade Sharpening section for instructions on how to reset the blades.*

Setting the blades is done in two steps. First, move the blades to the "zero position", then advance or retract to control the blade offset. Use the numbered scale wrapped around each post to assist with setting the blades.

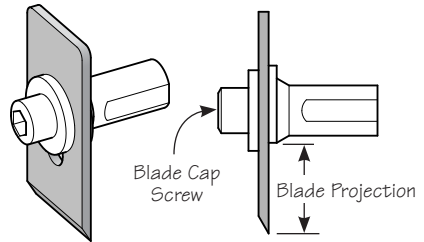
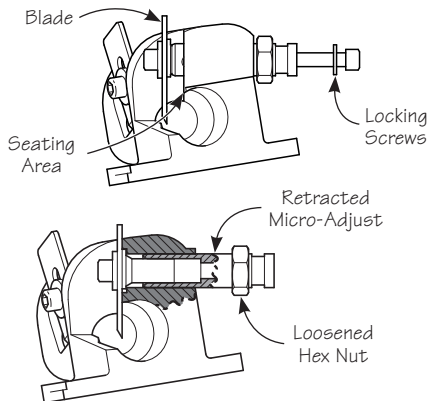

**Figure 6: Blade cap screw and projection.**

### Zeroing the Blades

The front and rear blades are zeroed in the same manner. Loosen and remove the locking screw and washer, then loosen and back off the hex nut. Retract the micro-adjust while pressing the blade against the retreating post.

*Note: The dowel maker is assembled and packaged with both front and rear blades already set in the zero position. In this position, the blades will already be contacting the seating area and retracting the micro-adjust will not result in any movement of the blade.*



**Figure 7: Resetting the micro-adjust.**

Continue to retract the micro-adjust a revolution or two beyond the point where the blade first contacts the seating area on the body. Hold the blade firmly against this seating area, and slowly advance the micro-adjust until it just contacts the blade and resistance is felt (see **Figure 8**). If you see the blade beginning to lift off the seating area, you have advanced it too far.

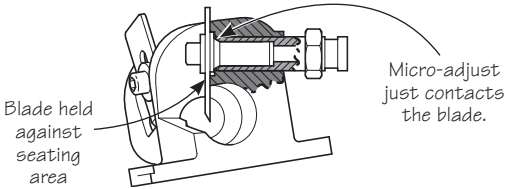

**Figure 8: Zeroing the blades.**

When the blade is zeroed, the “0” mark on the micro-adjust scale should be facing up, as shown in **Figure 9**.

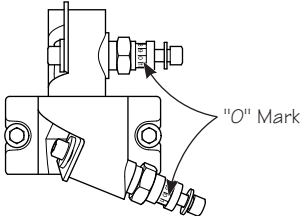

**Figure 9: Confirming the blade zeroing.**

**Setting the Blade Offsets**

From the zero position, use the micro-adjusts to offset the blades to the required amount (see **Table 2**).

**Table 2: Initial Blade Setting.**

Dowel Size	Front Offset	Rear Offset
1/4"	0.1	0.1
5/16"	1	0.7
3/8"	2	1.3
7/16"	3	2
1/2"	4	2.6
9/16"	5	3.2
5/8"	6	3.8
11/16"	7	4.5
3/4"	8	5.1
13/16"	9	5.7
7/8"	10	6.3
15/16"	10.6	6.9
1"	11.2	7.5

*For convenience, this table is reproduced on a label affixed to the dowel maker body.*

For example, if you are making 3/4" dowel, the front blade would be offset 8 revolutions and the rear would be offset 5.1 revolutions from their respective zero positions.

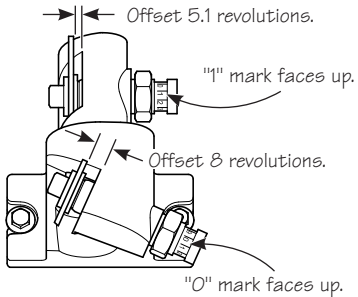

**Figure 10: Blade offsets for 3/4" dowel.**

Reinstall and tighten the locking screws. With the screws tightened, the blades will have a small amount of play. On the rear blade this play doesn't matter; simply tighten the hex nut. The front blade, however, should be rotated so its bottom corner contacts the sidewall of the body (see **Figure 11**), then tighten the hex nut.

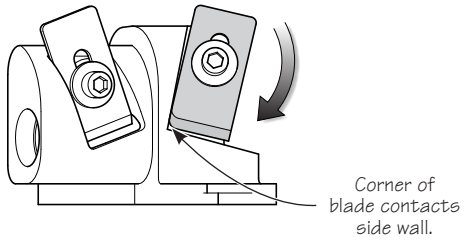

**Figure 11: Positioning the front blade.**

## Adjusting the Blades

The initial blade setting (see **Table 2**) will get you close to making dowel to the desired diameter. Due to variations in wood species, grain orientation and moisture content, fine tuning the blade setting is almost always required to obtain the desired dowel diameter.

To adjust the diameter:

1. Note the position of the graduations on the micro-adjust scale.
2. Loosen the locking screw.
3. Loosen the jam nut.
4. Advance the micro-adjust to increase the dowel diameter; retract it to decrease the diameter. Each division of the scale results in a 0.010" change to the diameter. If the micro-adjust does not rotate freely, loosen the locking screw another revolution or so and give the screw a tap. (This will break the friction between the blade mounting stem and the micro-adjust post.)
5. Tighten the locking screw.
6. Tighten the hex nut, remembering to rotate the front blade against the sidewall of the body.

## Cutting 1" Dowel

Rip several lengths of 1 1/8" square stock (as determined from **Table 1**). We suggest that you begin with a clear softwood, such as pine or poplar, roughly 3 feet long. Try to use wood that has no knots or, at the most, small, tight pin knots.

Zero both blades, then offset them to their initial settings (as listed in **Table 2**: 11.2 revolutions for the front blade and 7.5 revolutions for the rear blade).

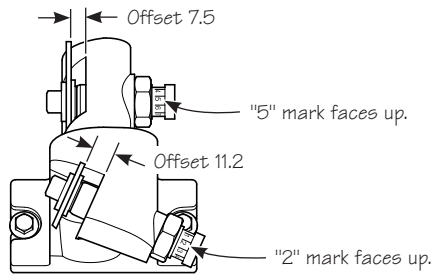

**Figure 12: Blade offsets for 1" dowel.**

## Taking a Test Cut

Firmly tighten the 3/8" drive adapter in an electric drill and snap the 1/8" square socket on the end of the adapter.

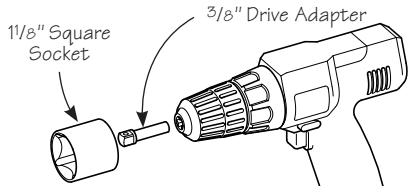

**Figure 13: Drive adapter and square socket.**

Insert one end of the stock into the socket and the other end in the bore of the body. Adjust the angle and position of the drill so the stock is aligned with the bore of the dowel maker.

*Note: Maintaining the stock aligned left to right can be done by eye fairly easily. Up and down alignment is harder, unless your drill has an integral level. Stick-on levels are available for drills that do not have this feature.*

With the drill spinning the workpiece, slowly feed it into the dowel maker until 1" to 2" projects out of the rear end. Switch off the drill, withdraw the stock and measure both rough and finished diameters.

The rough diameter should be between 1.025" and 1.075". While the initial blade setting will get you **close** to this size, variations in wood species, grain orientation and moisture content will almost always make it necessary to fine tune the blade setting to obtain the desired dowel diameter.

When fine tuning the blade settings, the front (roughing) blade must be adjusted first and the rear (finishing) blade is adjusted second. The chart below illustrates how to go about fine tuning the dowel maker.

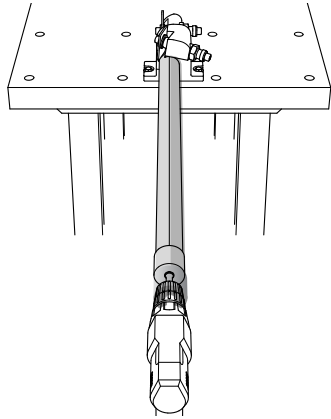

**Figure 14: Preparing to cut dowel.**

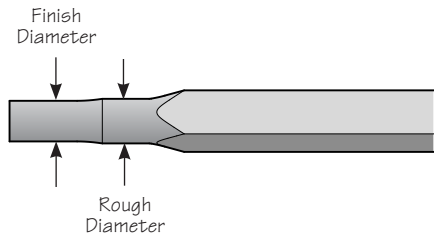

**Figure 15: Rough and final diameters.**

Check	Action
Is the rough diameter more than 0.075" oversize?	Retract the front blade.
Is the rough diameter less than 0.025" oversize?	Advance the front blade.
Is the final diameter oversize?	Retract the rear blade.
Is the final diameter undersize?	Advance the rear blade.

The procedure for adjusting the blades is outlined above.

Each time a blade is advanced or retracted, the rounded portion of the stock should be cut off and the test repeated.

If the rough diameter is more than 0.075" oversize, the dowel may seize in the dowel maker. At less than 0.025" oversize, there will be insufficient material to be cleaned up by the rear blade, resulting in a high feed rate and poor finish.

Once the dowel diameter is **at** or **below** the desired 1", place the 1" guide bushing into the rear counterbore in the body. The final dowel diameter must **not** be **larger** than 1" or the dowel will seize in the guide bushing. Orient the tapered end inward and align the side countersink with the bushing set screw (see **Figure 16**). Tighten the set screw. It helps to rotate the bushing slightly in both directions to ensure that the tip of the set screw is engaged in the side countersink.

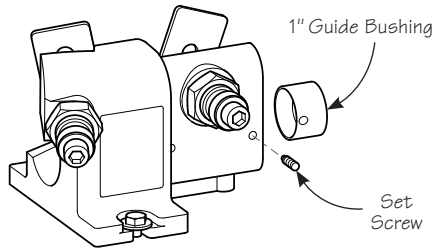

**Figure 16: Guide bushing installation.**

Again, cut off the dowel from the square stock and make another test cut. Adjust the rear blade as required to fine tune the final diameter. If you are having trouble obtaining the desired diameter and finish, consult the *Troubleshooting* section at the end of this manual.

### Positioning Dowel Supports

After achieving the desired dowel diameter, perform a final test cut until approximately 15" of dowel projects out the rear end of the body. Switch off the drill and place a dowel support under the end of the dowel. Rotate the support until the diagonally opposed corners make light contact with the dowel, as shown in **Figure 4**. Clamp or screw the support to the work surface.

Subsequent dowel will enter this support as it is being produced. The light contact will prevent excessive vibration and whip.

When the dowel maker is producing dowel of the desired size, and the dowel supports are at their proper locations, try a new piece of square stock, approximately 3 feet long. To produce dowel with a uniform fine finish, use a high drill speed and a slow and constant feed rate. **Do not** stop until the workpiece is nearly consumed (about 1" or so before the drive socket contacts the body). Stopping and restarting midway may leave annular grooves.

### Cutting 15/16" Dowel

Zero both blades, and then offset them to their initial settings (as noted in **Table 2**: 10.6 revolutions for the front blade and 6.9 revolutions for the rear blade).

Repeat the test cut and dowel support procedure.

Once the dowel is **at** or **below** the desired 15/16" diameter, place the 15/16" guide bushing into the rear counterbore in the body, then lock it in place (see **Figure 16**).

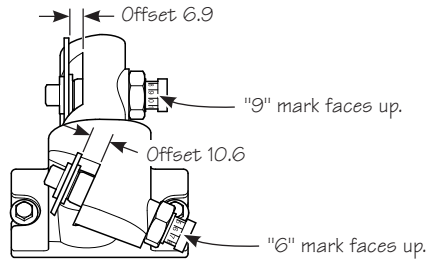

**Figure 17: Blade offsets for 15/16" dowel.**

## Cutting 1/4" to 7/8" Dowel

The optional inserts allow you to make dowel from 1/4" to 7/8" diameter in 1/16" increments. Each insert can be used to make the nominal size dowel, as well as the 1/16" undersize dowel. The 1/4" insert can be used only for 1/4" dowel.

Zero both blades, and then offset them to their initial settings, as noted in **Table 2**. Setting the blade offsets can only be done before the insert is installed.

After locking both micro-adjusts with the hex nuts, remove the front and rear locking screws and washers, then withdraw the blade assemblies from the micro-adjust posts. See **Figure 10**.

**⚠ Caution:** *Blades are extremely sharp! Use caution when handling them.*

With the blade assemblies removed, slide the appropriate insert into the body and orient it so the surface of the rear blade cut-out is flush with or slightly recessed from the matching cut-out in the body, as shown in **Figure 11**.

Firmly tighten the insert set screw against the flat on the insert while pressing the insert into the body (see **Figure 18**).

Replace the blade assemblies and firmly tighten the front and rear locking screws.

Repeat the test cut and dowel support procedure.

Once the dowel is **at** or **below** the desired diameter, place the appropriate guide bushing into the rear counterbore in the body, then lock it in place (see **Figure 16**).

## Blade Sharpening

**⚠ Caution:** *Blades are extremely sharp! Use caution when handling the blades, particularly when loosening and tightening the blade fixing screws, as this requires that you exert some force near to the exposed edge.*

Remove the front and rear locking screws and washers so that the blade assemblies may be withdrawn completely from the micro-adjust posts. For each blade assembly, clamp the shank of the mounting stem across the flats in a vise.

Remove the cap screw and washer. Each blade should be resharpened to its original 30° bevel angle. A micro-bevel may be applied as you might do for other woodworking blades. For the finest edge, we recommend progressing to a 4000x sharpening stone.

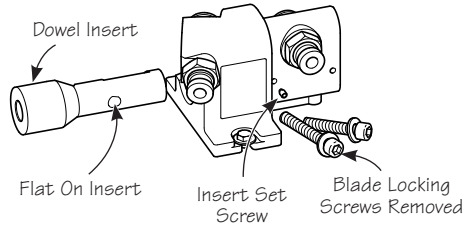

**Figure 18: Removing blade assemblies.**

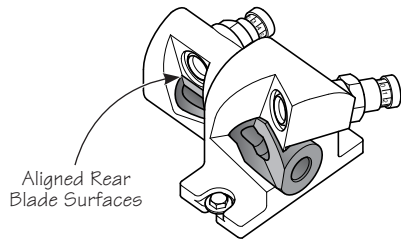

**Figure 19: Installing an insert.**

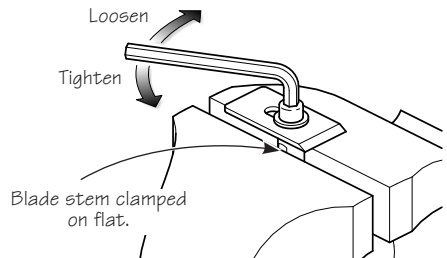

**Figure 20: Removing the blade from its mounting stem.**



The radius on the trailing corner of the front blade should be resharpener as well. This may be done free hand by rolling the radius as you draw it across the stone.

Be sure to remove the wire burr from the back of the blade by drawing the non-bevelled surface across the finest grit stone that was used on the bevel.

### Setting the Blade Projections

Clamp the shank of the front blade mounting stem across the flats in a vise. Place the front blade (the one with the radiused corner) onto the **long** registration ledge of the projection gauge, such that the cutting edge contacts the ledge, as shown in **Figure 21**. The integral magnet will hold the blade in place.

Place the blade (with the projection gauge attached) onto the clamped mounting stem, oriented so that the flat on the flange of the mounting stem contacts the end face of the projection gauge, as shown in **Figure 21**.

Replace the washer and cap screw, tightening it only to the point where the blade is still free to slide. Check that the flat on the mounting stem remains in contact with the end face of the projection gauge and firmly tighten the cap screw. Do not worry if the blade rotates slightly as the screw is tightened; it will do so about the axis of the mounting stem, leaving the projection unaffected.

Replace the front blade assembly in the front micro-adjust, securing it in place with the locking screw.

Repeat the above procedure for setting the rear blade projection, except use the **short** registration ledge on the projection gauge.

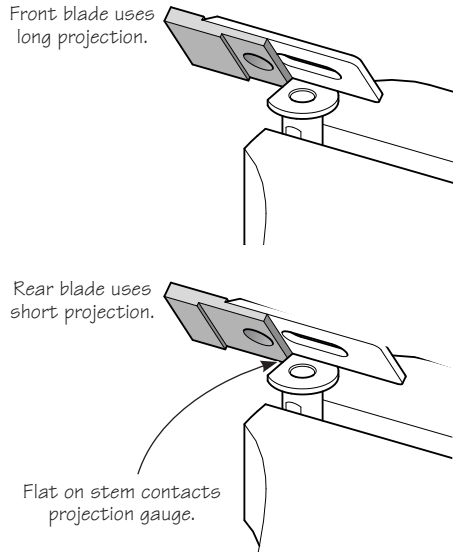

**Figure 21: Blade-setting gauge on front blade.**

# Troubleshooting

Problem	Cause(s)	Solution(s)
Dowel maker cuts slowly or not at all.	The front blade is offset too far.	Retract the blade to reduce the rough diameter so the workpiece advances at a controlled rate. The rough diameter should be 0.025" to 0.075" larger than the final diameter for the 1/8" dowel increments.
Dowel seizes immediately after rough cut.	The rough diameter of the dowel is too large to fit in the bore of the dowel maker or the inserts.	Retract the front blade to reduce the rough diameter so the workpiece advances at a controlled rate. The rough diameter should be 0.025" to 0.075" larger than the final diameter for the 1/8" dowel increments.
Dowel seizes immediately after finish cut.	The final diameter is larger than the bore of the guide bushing.	Retract the rear blade to reduce the final diameter.
Final dowel diameter is undersized.	The rear blade is retracted too far.	Measure the final diameter and increase the offset on the rear blade as required.
Poor finish.	Feed rate too high in relation to cutting speed.	Reduce the feed rate and/or increase cutting speed (drill rpm).
	Rough diameter is too small in relation to final diameter, leaving insufficient material to be cleaned up by the rear blade.	Advance the front blade to increase the rough diameter.
	Open grain properties of wood species, unusual grain orientation or knots.	Try another workpiece or use a different wood species.
	Excessive vibration.	Increase the number of dowel supports or try varying the cutting speed in order to change the harmonics.
Outfeed dowel breaking.	Grain structure or knots present in the stock.	Try another workpiece or use a different wood species.
	Insufficient dowel supports or their placement.	Check the position of the dowel supports and realign them if necessary.
Infeed dowel breaking.	Grain structure or knots present in the stock.	Try another workpiece or use a different wood species.
	Seizing.	Refer to seizing issues above.
Intermittent annular grooves.	Drill is stopped and restarted midway or drill speed and/or feed rate is varied considerably.	Use continuous and uniform speed and feed rate.

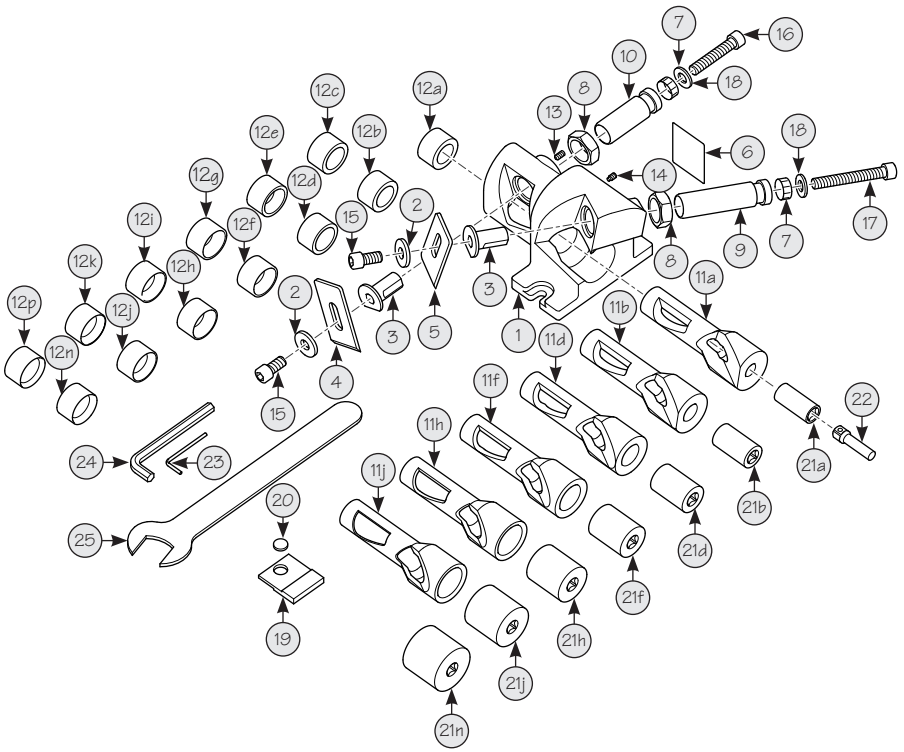

**Figure 22: Exploded parts diagram.**

Part	Qty.	Description	Notes
1	1	Body	
2	2	Blade Washer	
3	2	Mounting Stem	
4	1	Rear Blade	
5	1	Front Blade	front blade has rounded corners
6	1	Blade Elevation Label	
7	2	Micro-Adjust Scale	
8	2	Micro-Adjust Lock Nut	
9	1	Front Micro-Adjust	
10	1	Rear Micro-Adjust	
11	6	Dowel Inserts	dowel inserts are not included in basic dowel maker
11a		1/4" Dowel Insert	
11b		5/16" and 3/8" Dowel Insert	
11d		7/16" and 1/2" Dowel Insert	
11f		9/16" and 5/8" Dowel Insert	
11h		11/16" and 3/4" Dowel Insert	
11j		13/16" and 7/8" Dowel Insert	
12	13	Guide Bushings	only the 15/16" and 1" guide bushings are included in the basic dowel maker
12a		1/4" Guide Bushing	
12b		5/16" Guide Bushing	
12c		3/8" Guide Bushing	
12d		7/16" Guide Bushing	
12e		1/2" Guide Bushing	
12f		9/16" Guide Bushing	
12g		5/8" Guide Bushing	
12h		11/16" Guide Bushing	
12i		3/4" Guide Bushing	
12j		13/16" Guide Bushing	
12k		7/8" Guide Bushing	
12n		15/16" Guide Bushing	
12p		1" Guide Bushing	
13	1	Bushing Lock Set Screw	
14	1	Insert Locking Set Screw	
15	2	Blade Cap Screw	
16	1	Rear Locking Screw	
17	1	Front Locking Screw	
18	2	Locking Screw Washer	
19	1	Blade Setting Gauge	
20	1	Magnet	
21	7	Square Sockets	only the 1 1/8" square socket is included in the basic dowel maker
21a		3/8" Square Socket	
21b		1/2" Square Socket	
21d		5/8" Square Socket	
21f		3/4" Square Socket	
21h		7/8" Square Socket	
21j		1" Square Socket	
21n		1 1/8" Square Socket	
22	1	3/8" Drive Adapter	
23	1	3/32" Hex Key	
24	1	5/16" Hex Key	
25	1	1 1/8" Wrench	

## Accessories

- 05J45.01** Basic Dowel Maker (*includes parts 12n, 12p and 21n*)
- 05J45.03** 1/4" Dowel Insert Kit (*includes parts 11a, 12a and 21a*)
- 05J45.05** 5/16" & 3/8" Dowel Insert Kit (*includes parts 11b, 12b, 12c and 21b*)
- 05J45.07** 7/16" & 1/2" Dowel Insert Kit (*includes parts 11d, 12d, 12e and 21d*)
- 05J45.09** 9/16" & 5/8" Dowel Insert Kit (*includes parts 11f, 12f, 12g and 21f*)
- 05J45.11** 11/16" & 3/4" Dowel Insert Kit (*includes parts 11h, 12h, 12i and 21h*)
- 05J45.13** 13/16" & 7/8" Dowel Insert Kit (*includes parts 11j, 12j, 12k and 21j*)
- 05J45.17** Fitted Case only (*holds all of the above except the bulky main body*)
- 05J45.20** Master Set (*all of the above*)
  
- 05J45.21** 5/16" Dowel Insert Kit for Arrow Makers
- 05J45.22** 11/32" Dowel Insert Kit for Arrow Makers
- 05J45.23** 23/64" Dowel Insert Kit for Arrow Makers
- 05J45.25** Set of 3 Dowel Inserts for Arrow Makers
  
- 05J45.18** Replacement Front Blade (*part 5*)
- 05J45.19** Replacement Rear Blade (*part 4*)
  
- 05G20.02** Dog-Hole Mount Assembly